

NOTES:

1. See SHEET 2 for rebar detail.
2. Reflects .75" felt allowance.
3. Spacing varies for each tank size. See PIER INSTALLATION drawing.
4. MATERIAL: 5000psi CONCRETE
5. 3" I.D. Schedule 40 THRU (2)
6. GRADE may vary.
7. Engineering "sign offs", data and/or additional information available upon request.

TOLERANCES: INCHES
 FRACTIONAL $\pm 1/8$
 ANGULAR $\pm 1^\circ$

PROPRIETARY AND CONFIDENTIAL
 THE INFORMATION CONTAINED IN THIS DRAWING IS THE SOLE PROPERTY OF LPG VENTURES, INC. ANY REPRODUCTION IN PART OR AS A WHOLE WITHOUT THE WRITTEN PERMISSION OF LPG VENTURES, INC. IS PROHIBITED.

REVISIONS

NO.	DESCRIPTION	DRW/QCM	DATE
0	APPROVED FOR FAB.	C.H. C.H.	05/14/15

LPG Ventures, Inc.
 971 North Jefferson Street
 Kearney, MO 64060
 (816) 903-1806
 Fax: (816) 903-1810
 Toll Free: (888) 739 8764

DESCRIPTION: PRECAST PIER FOR 78" OD TANK	
DWG NO:	PIER 78
SCALE:	SHEET 1 OF 2
REV:	0

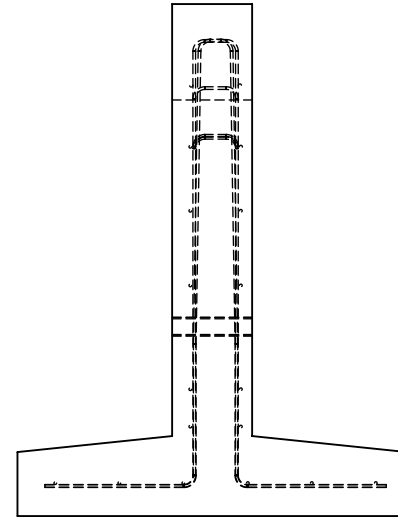
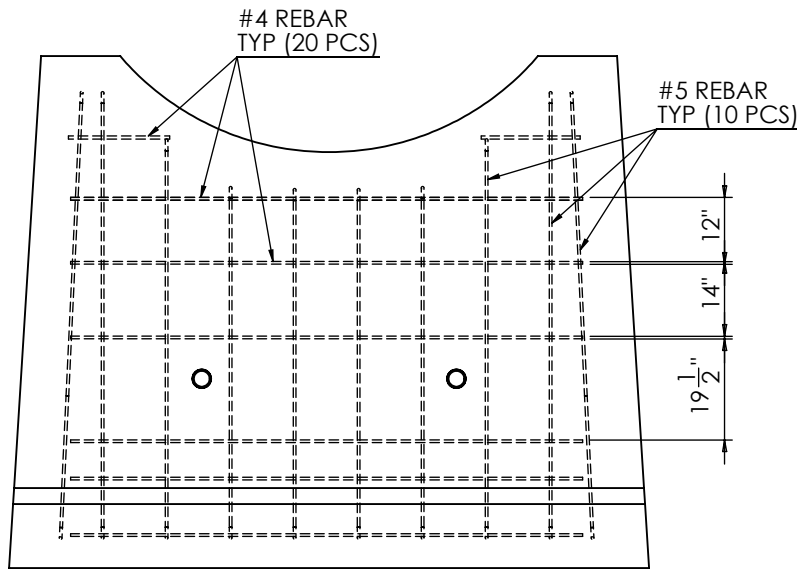
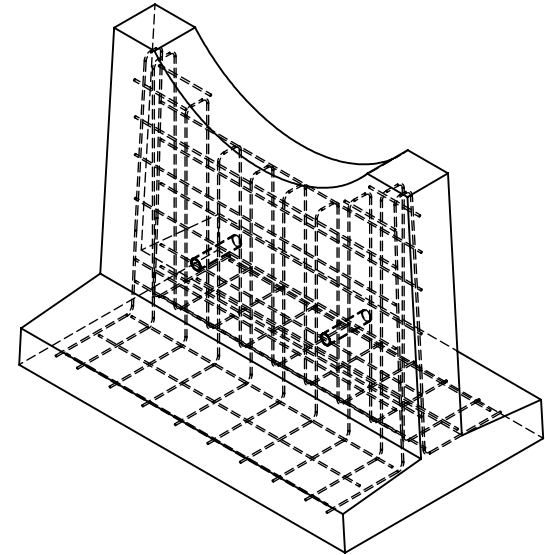
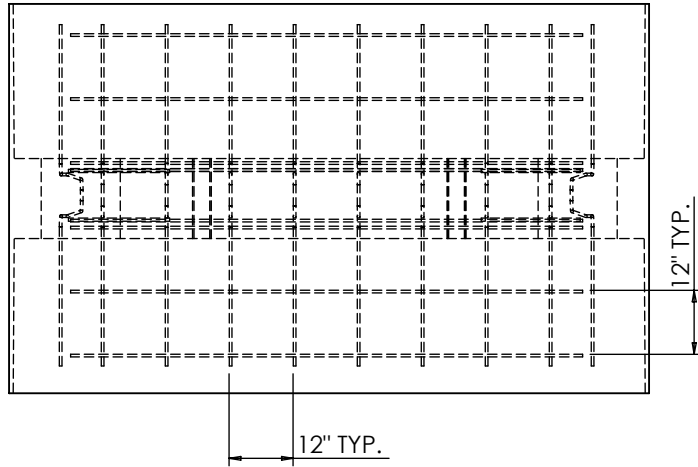

TOLERANCES: INCHES
 FRACTIONAL $\pm 1/8$
 ANGULAR $\pm 1^\circ$

PROPRIETARY AND CONFIDENTIAL
 THE INFORMATION CONTAINED IN THIS DRAWING IS THE SOLE PROPERTY OF LPG VENTURES, INC. ANY REPRODUCTION IN PART OR AS A WHOLE WITHOUT THE WRITTEN PERMISSION OF LPG VENTURES, INC. IS PROHIBITED.

REVISIONS			
NO.	DESCRIPTION	DRW/QCM	DATE
0	APPROVED FOR FAB.	C.H. C.H.	05/14/15

LPG Ventures, Inc.
 971 North Jefferson Street
 Kearney, MO 64060
 (816) 903-1806
 Fax: (816) 903-1810
 Toll Free: (888) 739 8764



DESCRIPTION: PRECAST PIER FOR 78" OD TANK	
DWG NO:	PIER 78
SCALE:	SHEET 2 OF 2
REV:	0